

## TRAVELLING COLUMN MILLING MACHINE WITH FIXED TABLE



**GCM 4**  
**GCM 5**  
**GCM 6**  
**GCM 8**  
**GCM 10**



GORATU'S great experience in the machine tool sector, together with the remarkable competence of the R&D department of its Integral Technological Centre have resulted in a new generation of TRAVELLING COLUMN MILLING MACHINE of excellent quality, great performance, accuracy, flexibility and high output.

## INDEX

	Pag.
1. Technical features .....	1
1.1. Machine description .....	1
1.2. Machine lay-out .....	2
1.3. Spindle travel Length .....	3
1.4. Milling Head's dimensions .....	3
2. Bed-Table .....	4
3. Rear guide way and rear slide .....	4
4. X axis slide .....	5
5. Column.....	5
6. Vertical slide .....	5
7. Ram .....	6
8. Spindle head .....	6
9. Digital drive of main spindle .....	6, 7
10. Digital feed drive of X, Y and Z axis.....	7
11. Measuring system .....	8
12. Thermal compensation.....	8
13. Protection of slides and slide ways .....	8
14. Tool clamping system .....	8
15. Counterweight for compensation of vertical Z axis.....	8
15.1. Safety brake of the vertical Z axis.....	9
16. Coolant system.....	9
17. Lubrication .....	9
18. Safety guards .....	9
19. Installation data .....	10
19.1. Sitting of machine.....	10
19.2. Electrical data.....	10
20. Starting up and commissioning.....	11
21. Verifications .....	11
22. Safety standards .....	12
23. Paintwork.....	12
24. Documentation .....	12
25. Tools for machine operation .....	12
26. Numerical control ( <b>ANNEX 1</b> ).....	12
27. Options and accessories ( <b>ANNEX 2</b> ).....	12
28. Common options and accessories ( <b>ANNEX 3</b> ).....	12
29. Lay-Outs ( <b>ANNEX 4</b> ).....	12
30. Machine warranty .....	13

## 1. TECHNICAL FEATURES

### 1.1. MACHINE DESCRIPTION:

TRAVELLING COLUMN MILLING MACHINE LAGUN	GCM 4	GCM 5	GCM 6	GCM 8	GCM 10
<b>TABLE</b>					
WORKING SURFACE (mm)	5500x1100	6500x1100	7500x1100	9500x1100	11500x1100
T SLOTS, NUMBER AND WIDTH (mm)	7x22				
DISTANCE BETWEEN SLOTS (mm)	160				
MAXIMUM WEIGHT ON TABLE (Kgs/m <sup>2</sup> )	6000				
<b>TRAVERSE</b>					
LONGITUDINAL – X AXIS (mm)	4000	5000	6000	8000	10000
CROSS – Y AXIS (mm)	1200				
VERTICAL – Z AXIS (mm)	1500/2000*				
<b>RAPID FEEDS</b>					
LONGITUDINAL – X AXIS (mm/min)	20000				
CROSS – Y AXIS (mm/min)	20000				
VERTICAL – Z AXIS (mm/min)	20000				
<b>SPINDLE (MAIN SPINDLE)</b>					
SPINDLE TAPER	ISO 50 DIN 69871/A				
SPEED RANGE (min <sup>-1</sup> )	3000/4000*				
<b>MAIN MOTOR</b>					
MAIN MOTOR POWER (kW)	28/34,5				
SERVOMOTOR POWER (kW)	5,37				
COOLING MOTOR PUMP (kW)	1,1				
CENTRAL LUBRICATION PUMP (kW)	0.15				
CENTRAL HYDRAULIC UNIT (kW)	0.75				
<b>MACHINE ACCURACY</b>					
POSITIONING (mm)	A: 0,015				
REPEATABILITY (mm)	R: 0,008				
<b>MEASUREMENTS</b>					
PLANT LAY-OUT (mm)	9565x6616	10565x6616	11565x6616	13565x6616	15565x6616
MACHINE HEIGHT (mm)	3905,5/4815*				
<b>WEIGHTS</b>					
NET WEIGHT (Kgs)	28000	31000	34000	40000	46000
GROSS WEIGHT WITH SEA PACKING (Kgs)	31000	34000	39000	45000	52000
<b>TOTAL INSTALLED POWER (kW)</b>	54				

(\*) *Optional*

## 1.2. MACHINE LAYOUT:

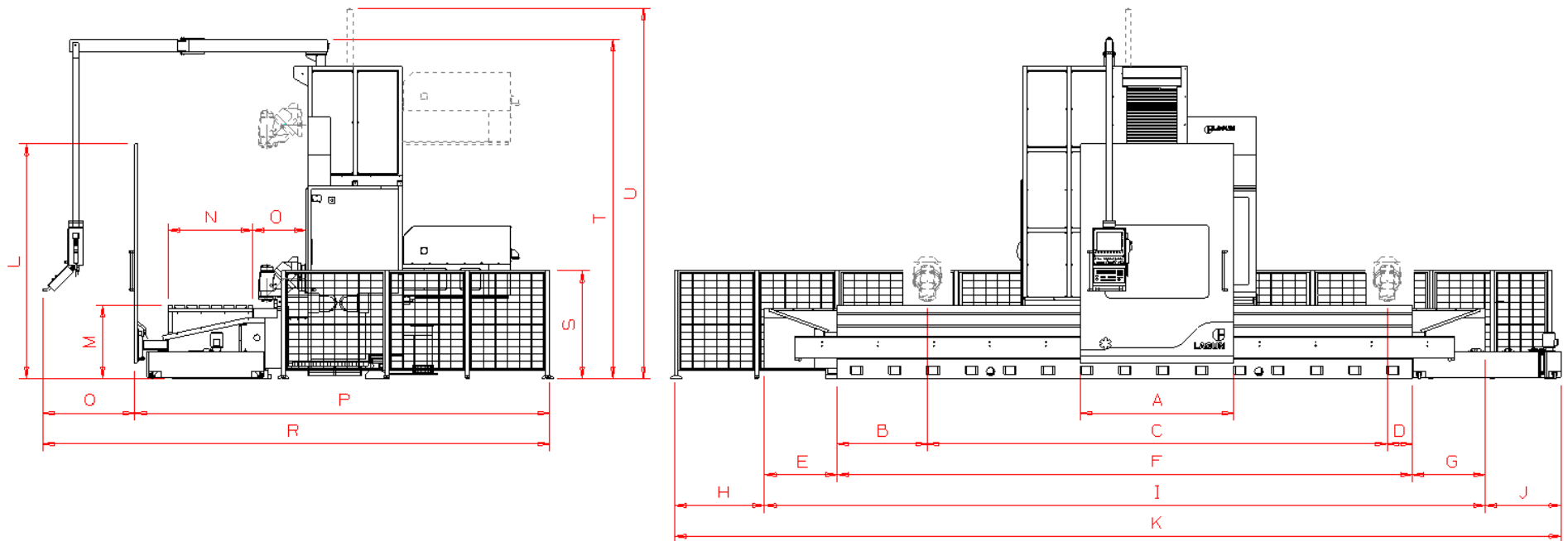

<b>LAGUN</b>	A	B	C	D	E	F	G	H	I	J	K	L	M	N	O	P	Q	R	S	T	U
<b>GCM 4</b>			4000			5500			7400		9565										
<b>GCM 5</b>			5000			6500			8400		10565										
<b>GCM 6</b>	2000	1175	6000	325	950	7500	950	1175	9400	990	11565	2550 3050*	950	1100	692,5	5412,5	1203,5	6616	1400	3905,5 4405,5*	----- 4815*
<b>GCM 8</b>			8000			9500			11400		13565										
<b>GCM 10</b>			10000			11500			13400		15565										

(\*) *Optional*

### 1.3. SPINDLE TRAVEL LENGTH

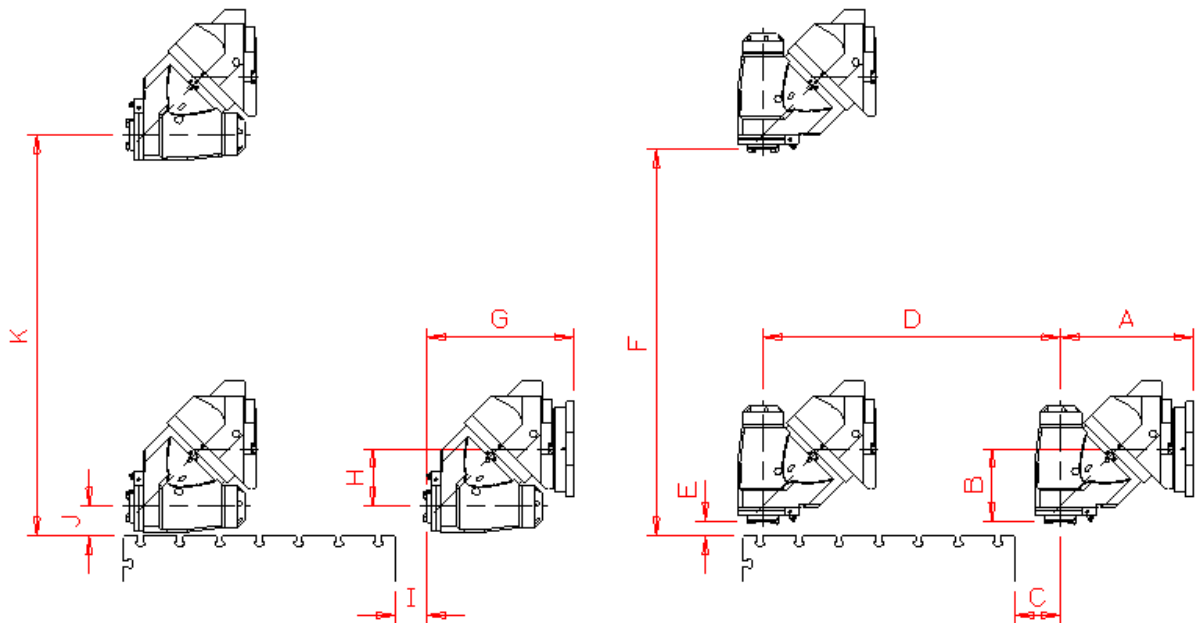

LAGUN	A	B	C	D	E	F	G	H	I	J	K
TRAVERSE Z 1500	533	290	184	1200	62	1562	591	232	126	120	1620
TRAVERSE Z 2000						2062*					2120*

(\*) *Optional*

### 1.4. MILLING HEAD'S DIMENSIONS

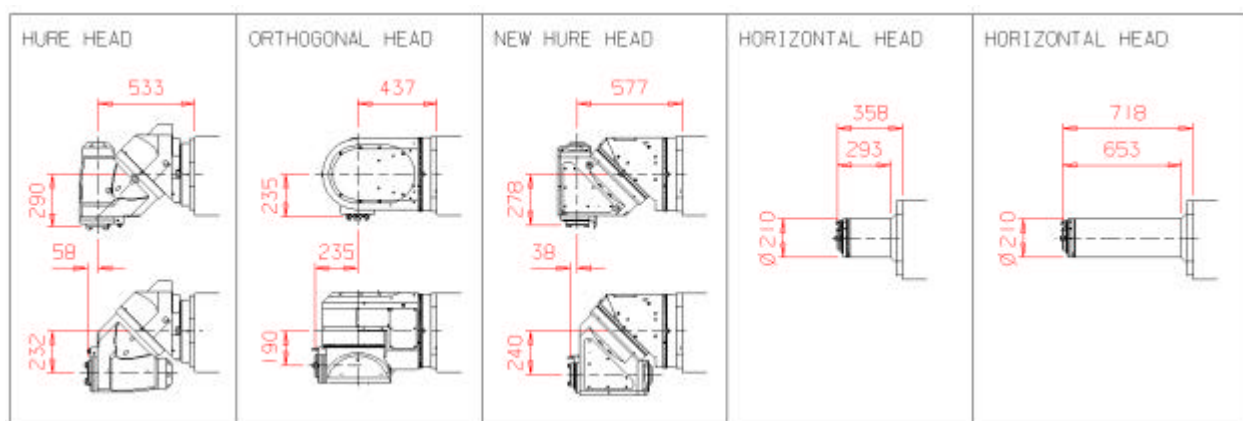

## 2. BED-TABLE

- The bed-table is made of pearlitic grey cast iron, quality EN-GJL-300 (UNE-EN 1561 standard) with hardness of  $190 \div 220$  HB, robustly reinforced with ribs at the bottom every 500 mm and studied by finite elements. Stabilisation is performed after machining thus avoiding that the stress during the first roughing process causes deformations.
- The column slides on the bed-table, with 2 size 55 linear roller guide ways in front and 1 slide with 6 carriages with recirculation rolls (RUSV type) in the rear part. Column displacement by means of double pinion rack system.

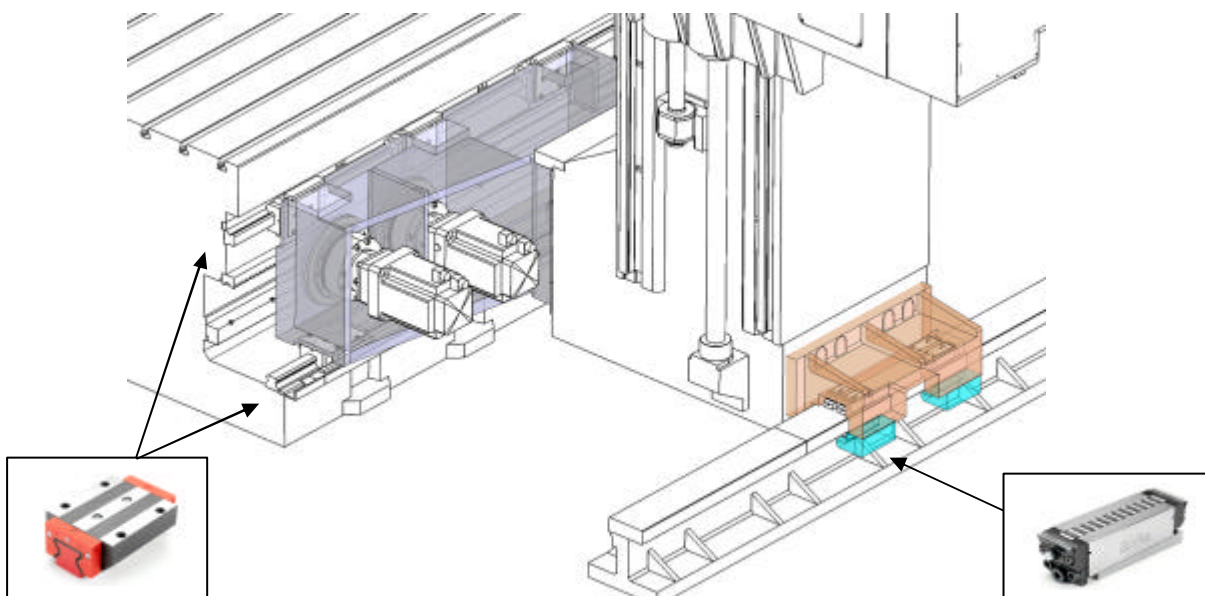

- In the upper part of the table is provided with 7 T-slots of 22 mm; the central one serves as a reference with 22 H7. Also in the front of the table there are 2 T-slots of 22 mm
- In the bottom part of the base holes are located for machine anchoring to the floor, with threaded supports for leveling.

## 3. REAR GUIDEWAY AND REAR SLIDE

- The base of the rear guide way is ST-52 material, with thermal stabilization, reinforced with ribs, and studied with finite elements. On this base ties a bolted steel way, which it is hardened with a hardness of 60 HRC and ground, with rectangular section of 140x50mm. In the bottom part of the base are located the holes for machine anchoring to the floor, with threaded supports for leveling.
- Material of rear slide is made of pearlitic grey cast iron, quality EN-GJL-300 (UNE-EN 1561 standard), with a hardness of  $190 \div 220$  HB, with thermal stabilization, robustly reinforced with ribs and subjected to finite elements.
- On the rear slide are located 6 carriages with recirculation rolls for displacement.

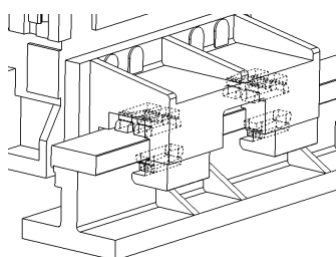

#### 4. X AXIS SLIDE

- The X-axis slide is made from pearlitic grey cast iron, quality EN-GJL-300 (UNE-EN 1561 standard), with a hardness of  $190 \div 220$  HB, with thermal stabilization, robustly reinforced with ribs and subjected to finite elements.
- On the slide are located 6 long guide carriages and two independent motors for the displacement of X-axis.

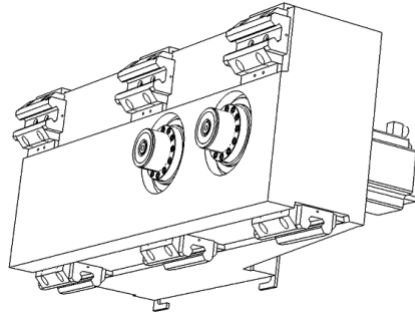

#### 5. COLUMN

- The column is made of pearlitic grey cast iron, quality EN-GJL-300 (UNE-EN 1561 standard), with a hardness of 190-220 HB, and is dimensioned and robustly reinforced with inner ribs to absorb the cutting and weight forces and studied by finite elements.
- The column and the bed are separated by an adequate distance, which enables machining of large voluminous parts with a width greater than the table, and milling of their rear side.
- The column has two size-45 rolling linear guide ways for vertical slide.

#### 6. VERTICAL SLIDE

- The vertical slide is made of pearlitic grey cast iron, quality EN-GJL-300 (UNE-EN 1561 standard), and has a hardness of 190-220HB, robustly reinforced with ribs at the bottom and subjected to finite elements.
- There are 8 guide carriages for Z movement and another 6 for the Y movement, as shown below.

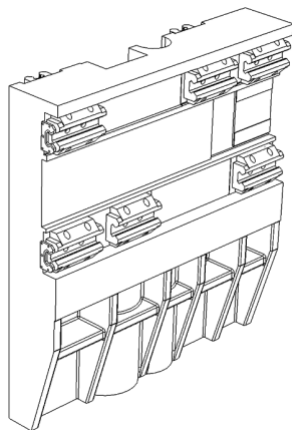

**Y AXIS MOVEMENT**

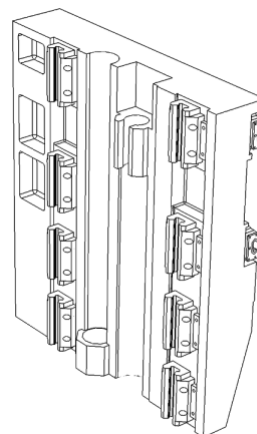

**Z AXIS MOVEMENT**

## 7. RAM

- The ram is made of pearlitic grey cast iron, quality EN-GJL-300 (UNE-EN 1561 standard), with a hardness of 190-220 HB, and is dimensioned and robustly reinforced with inner ribs to absorb the cutting and weight forces and subjected to finite elements.
- The ram has two size-45 rolling linear guide ways with recirculation rolls carriages, closed and protected against contamination.

## 8. SPINDLE HEAD

- Both bodies of spindle head are made of spheroidal graphite cast iron, quality EN-GJS-HB155 (UNE-EN 1563 standard), with a hardness of 130-180 HB.
- The Spindle head is made up of two parts joined at 45°, which rotates around each other and are joined to the front part of the ram.



- The head fitted on the machine can be “HURE” type, “ORTHOOGONAL” type, “HORIZONTAL L 290mm” and “HORIZONTAL L 650mm”. The standard head fitted on the machine is a “HURE” type with the following main features:
  - Hardened and ground Klingenberg-type epicyclical taper gears
  - Hardened and ground spindle shaft DIN 5480 (gear type).
  - Main spindle bearing diameter 85 x 130 mm.
  - Super-precision angular-contact ball bearings on the entire head.
  - Hydro-mechanic type tool clamping system (clamping force 13 / 16 kN).
  - Adapted to the machine and commanded by the CNC.
  - Complete installation with safety interface.
  - Rigid tapping.
  - Spindle taper and pull stud options:
    - Spindle taper DIN 69871 A/50 and pull stud DIN 69872 A (STANDARD)
    - Spindle taper DIN 69871 A/50 and pull stud ANSI B5.50
    - Spindle taper MAS 403 BT/50 and pull stud MAS 403 BT (45°)
    - Spindle taper DIN 2080/50 and pull stud DIN 69872 A

## 9. DIGITAL DRIVE OF MAIN SPINDLE

- The main motor is equipped on the upper part of the ram, and has a two-speed reducer box fitted that transmits the power to the main spindle to the machine through pulleys and belts.
- The change of the “Speed range” is performed by means of a two-speed box for the motors.

- The main advantages of use this element is as follows:
  - Separated lubrication systems for the gearbox (oil) and the main shaft (grease).
  - Avoids noise emission.
  - No heat transmission from main spindle (insignificant thermal expansion for this reason).
  - No vibration transmission from gears of main spindle, and therefore machining quality is not affected.
  - High tangential forces can be withstood thanks to the robustness of the bearings of the box output shaft.
  - High efficiency degree (greater than 95%).
  - Change of range through an electroiman.

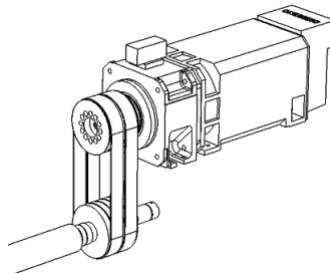

**10. DIGITAL FEED DRIVE OF THE X, Y AND Z AXIS**

- X axis is with double rack pinion system and electrical preload, two independent motors and high precision planetary reducer, regulated with master-slave system.

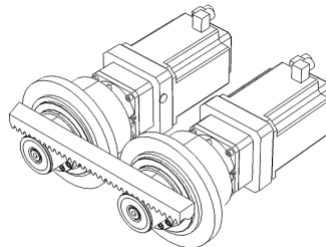

- Y and Zaxis have a ball screw system. The Y-axis ball screw is 50x16mm, and Z-axis 50x12mm, hardened and ground, quality ISO in accordance with DIN 69051 standard, guided on one end with combined axial-radial bearings (drive side) and preloaded angular contact bearings on the other end. Transmission for the movement of the Y-Z motors to the relevant spindles is made through pulleys and belts and a transmission relation of  $i=1,5$ .

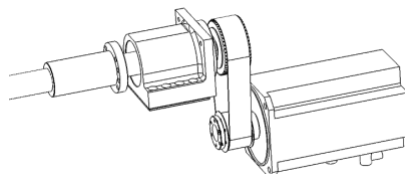

- The brushless servomotors are driven by regulators.
- RAPID FEEDS IN X – Y – Z AXIS (mm/min) ..... 20.000

## 11. MEASURING SYSTEM

- The measuring system uses direct reading linear encoder with an incremental system with a resolution of 0,001mm.
- These encoders are provided with a codification system with several reference sources, which allows a rapid start of the jobs without the need for long displacements of the axes for reference searches.

## 12. THERMAL COMPENSATION

- Thermal expansion compensation on the X / Y / Z -axis, governed by the CNC with two temperature probes, one on the headstock and the other one on the rear part of the machine to check environmental temperature.

## 13. PROTECTION OF SLIDES AND SLIDEWAYS

- The rear part of the bed-table is protected with bellows manufactured with NOMEX cloths, which can resist high temperatures. This bellows protect the guide ways, linear scales, and the rack of X-axis.
- The front part of cross slide is protected by a metal shutter with a thickness of 5.5mm. These shutters protect guide ways and ball screw...of the Z-axis.
- The ball screw of the Y-axis traverse is protected by a metallic telescopic guard.

## 14. TOOL CLAMPING SYSTEM

- The tool releasing system operates by means of a hydraulic piston integrated in the head itself, and driven by a hydraulic unit, which releases and clamps the tool by means of track tension spring washers.
- Tool clamping/releasing can be performed by means of an electric pedal so as to be able to handle the tool more comfortably.
- These operations can either be performed manually or automatically provided that the machine is equipped with a tool magazine.

## 15. COUNTERWEIGHT FOR COMPENSATION OF VERTICAL Z AXIS

- The Z-axis (vertical slide and ram) is balanced by means of a counterweight system, made up of a hydraulic cylinder and its rod attached to the vertical slide, and connected to a nitrogen accumulator, which together form a closed circuit, so that there is no need for an additional hydraulic unit during operation.
- If for any reason, a discharge of the circuit takes place and the pressure drops below the established limits for a correct operation of the system, a device manually charges the system again. The instructions to charge manually are detailed in machine maintenance manual.
- Nevertheless, the machine is equipped with a safety system, which blocks the operation of the entire system in case of an emergency.

### 15.1. SAFETY BRAKE OF THE VERTICAL Z AXIS

- An electromagnetic brake is fitted on the upper end of the ball screw of the vertical axis, which acts as a security in case of a power cut and avoids the vertical slide falling down.
- This safety system is fitted in case of a failure in operation of the counterweight for the vertical slide compensation.

## 16. COOLANT SYSTEM

- A reservoir has been fitted on the outer end of the bed with a tank, which holds 880 litres of coolant and a motor pump.
- Within the tank there is an electrical coolant level switch for coolant vigilante.
- The coolant is pumped from the tank with a flow rate of 30 liter/min and pressure of 4 bars to the end of the main shaft. The nozzles can be adjusted towards the tool point, and the flow can be set by means of a shut-off valve.

## 17. LUBRICATION

- The lubrication system consists of a central unit which by means of a time delayed signal given by the CNC automatically distributes the oil to several points such as ball screws, to the MR type roller shoes in three axis and RUSV type roller shoes of X axis. In order to have smooth running of the machine, all rolling elements are lubricated.
- The lubrication may also be set into operation manually by means of an electric push button on the control panel.
- Pinion and racks are lubricated from grease lubrication unit and by a felt greaser pinion.
- This unit has been provided with safety systems and circuit control so that any abnormality, low oil level in tank, clogging up of piping, etc. is immediately detected, triggering the corresponding alarm displayed on the screen.

## 18. SAFETY GUARDS

- One sliding door, which moves in either direction, has been equipped onto the front part of the machine.
- The rear part of the machine is protected with a fence, which has fitted a door with protected access and safety system.
- Operator cabinet moves with the column, protected with safety system.
- All the doors are equipped with windows to visualize the work area. Those windows are for safety requests of the machine and they are designed to resist an impact according with machine features.
- Low-voltage lamp for illumination of work area.
- For machine control is located an illumination indicator.

## 19. INSTALLATION DATA

### 19.1. SITTING OF MACHINE

- In order to get the most out of your machine, we recommend the following sitting:
  - A place with a firm floor.
  - Environmental temperature of  $22^{\circ} \pm 3$
  - Maximum relative humidity of air 75%
- Avoid the following locations:
  - Where machine is exposed to direct sunlight and/or any other heat source.
  - Places with nearby vibration sources. If he above location can not be avoided, provide the machine base with an anti-vibrating system.
  - Upper floors. If there is no other alternative, make sure it is placed near a pillar or reinforce the floor with an extra layer of concrete.
- Provide sufficient free space around the machine to fit accessories, machine supplements, to carry out repairs, to ensure operator mobility, etc.

### 19.2. ELECTRICAL DATA

- In order to connect our regulation equipment for energy return to the net, bear in mind the following requirements:
  - This equipment may be connected directly in case the factory network is of the TN type. This concerns a symmetric three-phase AC network with 4 or 5 wires with the star connection connected to ground (see fig. A).
  - With another type of network, use a separator transformer with the star connection of the secondary connected to ground (see fig. B).

VOLTAGE.....	400 V $\pm$ 10 %; 50 Hz $\pm$ 1 %
SERVICE VOLTAGE .....	110 V AC / 24 V DC
LAMP .....	Protection IP 67; 220 V
ELECTRIC CABINET .....	Protection IP 55
COOLANT OF ELECTRIC CABINET.....	Protection int. IP 34/ext. IP 54

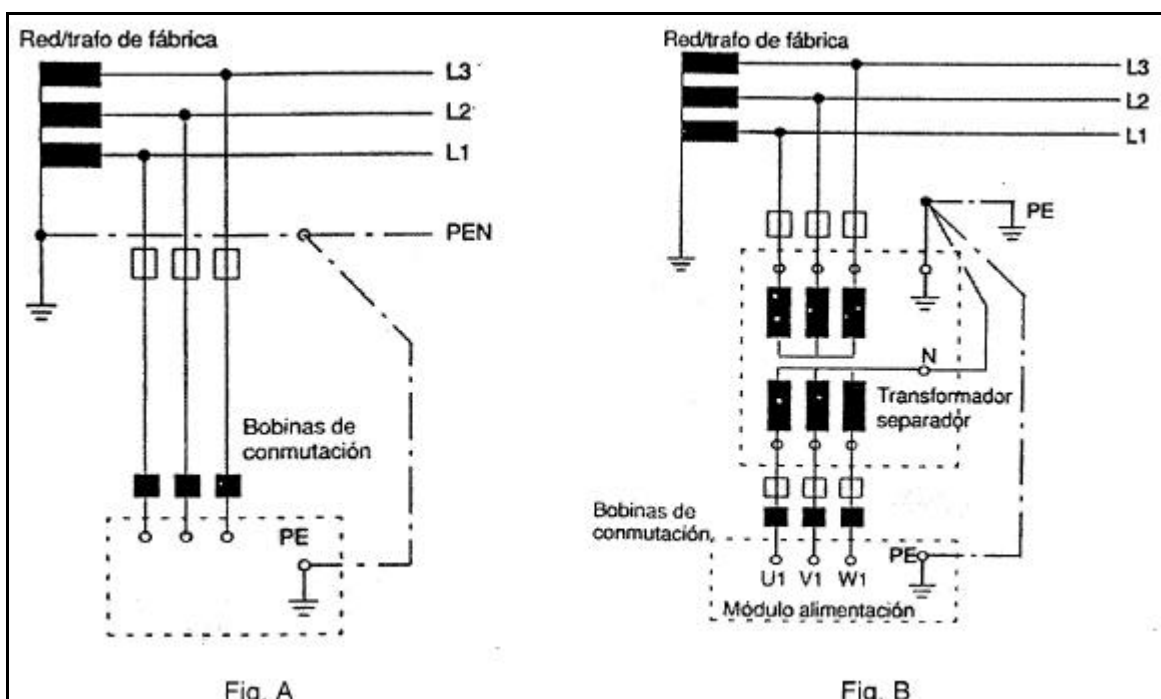

## 20. STARTING UP AND COMMISSIONING

- Customer request:
  - Machine sitting following GORATU`s foundation instructions.
  - Electrical connection following GORATU`s instructions.
  - Air connection following GORATU`s instructions.
- Machine visual inspection, in order to check any damage that may occur during transport.
- Check properly power supply and air connections (phase order and pressure).
- Check properly good performance of machine:
  - Movement of all axis.
  - Spindle rotation / Orientation.
  - Accessories / Auxiliary equipments.
  - Gears / Refrigeration
- Geometrical verification as per UNE standard specified for each type of machine.
- Operation training:
  - 1 Day (8 hours) for basic numerical control operation for standard machine without options. Training course with following contents:
    1. Control panel / CNC.
    2. Axis movement / Reference setting.
    3. Offsets calculation / work piece reference.
    4. Edition / program selection.
    5. Tool offset
    6. Program transmission (PC – CNC).
  - Options:
    1. Tool measuring probe. (2 hours).
    2. Work piece measuring probe. (3 hours).
    3. Digitalising probe. (6 hours).
    4. Electronic dividing table. (1 hour).
    5. Tool magazine. (1,5 hours).

## 21. VERIFICATIONS

- The machine is geometrically verified in accordance with Geometrical verification standard of GORATU, adaptation of Spanish standard UNE 15-302/90, from ISO 1984-1982, and compendium of DIN 8615, part 3 and 4 relative to “verification conditions of fixed bed height milling machine and mandrino in horizontal position and/or mandrino in vertical”
- Axis positioning verification is made by laser according to ISO 230-2 standard.
- POSITIONING ACCURACY (mm)..... A: 0,015 mm
- REPEATABILITY (mm)..... R: 0,008 mm

*(\*) For X>3000 mm traverse, increase 0,005 mm. For each additional 1000 mm.*

## 22. SAFETY STANDARDS

- The machine has been designed and constructed in accordance with:
  - Machinery directive 2006/42/CE
  - Electromagnetic Compatibility Directive 2004/108/CE
  - Low tension Electrical Facilities Directive 2006/95/CE
  - Safety standards on machining centres EN 12417+A2

## 23. PAINTWORK

- Machine and splashguard light dark texturized RAL 7466 and light grey.
- Doors, headstock, CNC desk, dark grey texturized RAL 7466.
- Accessories in dark grey texturized RAL 7466.

## 24. DOCUMENTATION

- 1 Complete machine manual, with assembly drawings and part lists.
- 1 set of CNC manuals.
- Machine parameters.
- Verification record.

## 25. TOOLS FOR MACHINE OPERATION

- Sling pack.
- Draw bars for tools according to machine taper.
- Double-end spanner 30-32 to perform manual headstock.
- Fix key size 46 for machine levelling.
- Samoa lubrication pump to lubricate headstock gears.

## 26. NUMERICAL CONTROL

- ❖ SEE ANNEX 1

## 27. OPTIONS AND ACCESSORIES

- ❖ SEE ANNEX 2

## 28. LAY – OUTS

- ❖ SEE ANNEX 3

## 29. MACHINE WARRANTY

- This warranty is valid for a maximum period of 12 months or 2000 operating hours (whichever first) based upon an 8 hour a day shift.
- The manufacturer will supply defective pieces without any charge in EX WORKS conditions; repair carried out during the warranty period and will not serve to extent this period. Renovated pieces will remain warranted in original conditions of machine. Any defective parts replaced will remain at the seller's disposal. Defective parts will be send by the customer to the manufacturer, once the customer have received his spare parts. On the contrary, if the customers don't send spare parts, the invoice will be charged to the customer.
- If the customer require of manufacture technician, labour cost, displacements cost and accommodation cost will be charged to the customer, in AFM established conditions. Machine warranty doesn't cover damages and operation failures of incorrect machine utilization and their accessories.
- Machine assembly will be done according to the instructions and foundation drawing supplied by GORATU. Not accomplishing these instructions can be the origin of geometrical tolerances deviations.
- The machine warranty doesn't cover damages and operation failure of incorrect machine utilization and their accessories.
- We recommend read the instructions Manual carefully, in particular the section on SAFETY. GORATU MAQUINAS HERRAMIENTA S.A. is under no obligation to pay any compensation for accidents, material damage to goods other than the object of the contract or loss of profit.
- With regard to the regulation of that specified in this warranty, the parties should refer to the general conditions for machinery supply outlined by CECIMO, with which the parties are familiar.



# **(STANDARD ACCESSORIES)**

## **NUMERICAL CONTROL**

## - CNC SIEMENS 840 D

### ● STANDARD USER FUNCTIONS

- Conversational programming language Shop Turn and DIN/ISO.
- NCU 571.5: Permits up to 6 axes and 6 heads.
- Operator panel OP32S with Colour screen LCD 10,4".
- Complete alphanumeric keyboard.
- Speed of communication device 1,5 Mbauds.
- Memory of 6 Mbytes for work piece programmes.
- Ethernet connections and serial RS 232-C.
- Software MCIS DNC Machine for transmission programmes through Ethernet.
- PCU 50 hard disk 40GB /15 GB for user (LOCAL BACKUPS AND SOFTWARE TO BE INSTALLED).
- Machining cycle's characteristic of milling machines through dialogue-based programming.
- Possibility of screen customisation.
- Teleservice through MODEM (phone line) or Ethernet.
- Diagnosis: Interconnection signals, NC alarms, PLC alarms...
- Backlash compensation, error of quadrant change, tool correction and RTCP tool orientation.
- Machine-operators interface in Russian language



### ● SIEMENS MOTORS

	MODEL	TORQUE (Nm)	POWER (kW)
<b>SIEMENS MAIN MOTOR</b>	1PH7 167-2ND23-0BC2	267	28

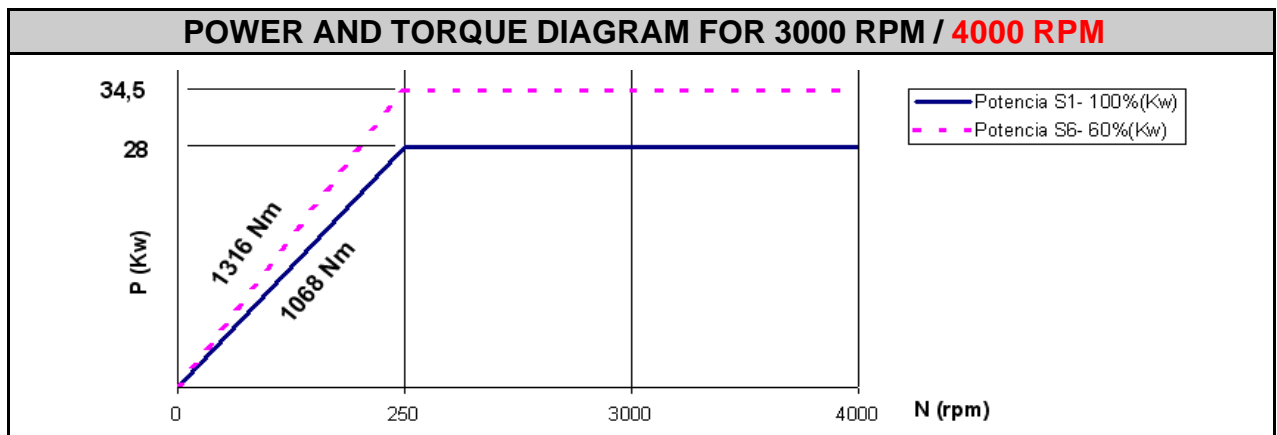

Two operation modes may be deduced from the power diagram:

- Constant torque [1068/1316 Nm] at speed of 0÷250 min<sup>-1</sup>
- Constant power [28/34,5 kW] at speed of 251÷3000 min<sup>-1</sup> / **4000 min<sup>-1</sup>**

The horizontal line shows the working zone at constant power, i.e. the total power of the main motor may be used [28/34,5 kW]. The slanted lines show the constant torque zone in which the power is proportionally reduced as the speed decreases. Hence, using speeds lower than 250 min<sup>-1</sup>, motor progressively decreases.

	MODEL	TORQUE (Nm)	POWER (kW)
<b>X AXIS SIEMENS SERVOMOTOR</b>	1FK7 103-5AF71-1AH0(with brake)	36	5,37
<b>Y AXIS SIEMENS SERVOMOTOR</b>	1FK7 103-5AF71-1AG0	36	5,37
<b>Z AXIS SIEMENS SERVOMOTOR</b>	1FK7 103-5AF71-1AG0	36	5,37

### ● AXIAL FORCE OR PUSHING FORCE OF X, Y, Z AXES

X Axis – Pinion-Rack (N).....	31140,43
Y Axis – Ball screw (N).....	13901,58
Z Axis – Ball screw (N).....	18535,44

- **OPERATOR PANEL IN FRONT OF BED-TABLE**

- Possibility to install all CNC-s.
- Installed on guide ways, it can be moved in all bed table traverses.
- Installed in machine with safety systems.



## OPTIONAL ACCESSORIES

## 1. AUTOMATIC TOOL CHANGER

- Fixed magazine in left side of the column.
- Tool change in vertical and horizontal position.
- Protected in external side.
- 24 positions
- System for manual extraction of tool.
- Maximum diameter of tool using all slots 110 mm.
- Maximum tool length 350 mm.
- Maximum tool weight 15 Kg.
- Maximum weight of all tools 240 Kg.
- Installed in machine with safety systems

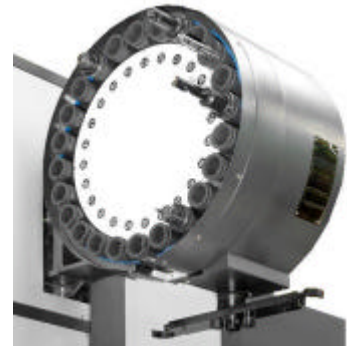

## 2. COOLANT THROUGH THE SPINDLE

- Coolant pressure pumps 10 bars with 35 l/min.
- Complete installation of pneumatic, pipes, filter, ...
- Installation of special joint in milling head.
- Installed in machine with safety systems.



## 3. SWARF CONVEYOR

- Swarf conveyors chain type and goose neck
- Installed between bed-tables and columns.
- Chip extraction from right side (Standard).
- Width of extractor 400 mm.
- Electrical motor.
- Installed in machine with safety systems.



#### 4. FRONTAL AND LATERAL GUARING

- Machine frontal guarding with sliding doors.
- Lateral and frontal windows
- 6 metres opening of the frontal doors
- Installed with security safety system
- Lateral guarding
- Enclosure according safety standards

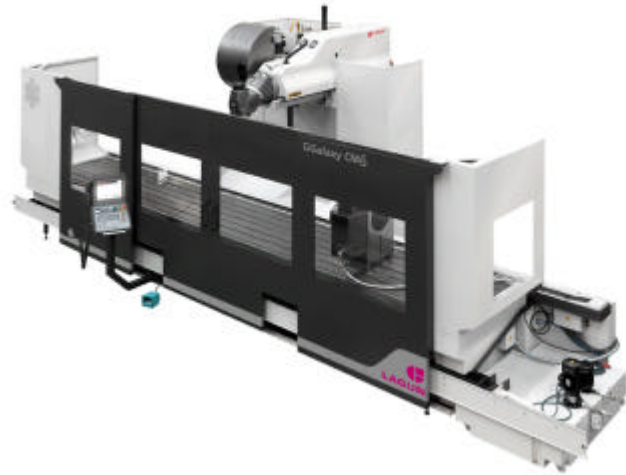

#### 5. INDEXING ROTARY TABLE

Electronic rotary table with the following main features:

- Diameter of the disc: 1.000 mm
- Allowed load with tailstock: 3.500 Kg
- Tangential torque: 15000 Nm
- Max rotation Speed: 15 RPM
- Braking system: hydraulic
- Braking torque: 8000 Nm
- Resolution: 0,001°
- Positioning accuracy: +- 5"
- Repeatability accuracy: 3"
- Weight: 2.000 Kg
- Dc servomotor driving



## 6.GHT 6 QUILL & TAILSTOCK

- Tailstock with preparation of the quill for chuck
- Adaption of the base for the milling machine table
- Adapter taper
- Manual clamping of the table
- Guided on grinded "T" slots of the table
- Manual blocking



## 7. HYDRAULIC CLAMPING CHUCK

- Hydraulic work piece clamping system
- Hydraulic chuck SMW IND 1.000 mm with blind hole
- Clamping diameter: 1.000 mm
- Hydraulic cylinder
- Connection draw bar
- Pedal driven
- 1 set of soft jaws
- Complete installation with safety interface



## 8. OPENED FIXED STADY REST 580 – 1.000 MM CAPACITY

Opened fixed steady rest with the following main features:

- Capacity: 580 – 1.000 mm
- Manual diameter adjustment
- 2 points nylon rollers
- Load capacity: 4.000 Kg
- Cast iron body



## 9. MANUAL 3 JAWS UNIVERSAL STEEL BODY CHUCK

3 Jaws self-centring chuck with the following main features:

- Clamping diameter 800 mm
- Min clamping diameter: 125mm
- Gripping force: 12.300 DaN
- Solid reversible jaws
- Steel body
- Max Speed: 764rpm
- 



## 10. "JUMA" FILTERING UNIT WITH TANK

- GAIN model of magnetic roller is mounted on the JUMA model of paper filter, the great advantage of this model is that the coolant liquid first of all goes through magnetic divider which eliminate the greater percentage of particles, next it is going through the paper filter. Used and contaminated paper filter is collected in an independent drawer of deposit.
- Filtration capacity of 150 l/min.
- Coolant deposit of 480 l.
- Complete installation of pipes ...
- Installed in machine with safety systems.

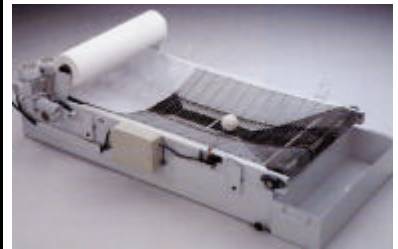

## 11. RENISHAW RMP 60 PART TOUCH PROBE

- Compatible with all CNC-s.
- Signal transmission from RADIO through antenna and interface.
- Software + cable + connector.



**12. RENISHAW TS 27 TOOL TOUCH PROBE**

- Tool measuring probe transmit a commutation signal to the CNC once the tool measuring probe is bended from the rest position of tool.
- Compatible with all CNC-s.
- Software + cable + connector.

